



PRODUCT SPECIFICATION

Product Name: LED Wall Light

Item Model: **KD-LWL-IP65A55R-12W**



● Features

1. Using Aluminum material, good appearance.
2. High quality driver, high efficiency and stability.
3. Using high quality light source, high light efficiency, and long life span.
4. Quick response time, the LED response time is nanosecond.
5. Environmental protection, no heavy metals and harmful gas.
6. Energy-saving, can save energy more 80% than traditional fluorescent lights.
7. No flicker, start quickly, soft light, protect your eyes.
8. Easy to install and use.

● Technical Parameter

Model	<u>KD-LWL-IP65A30-12W</u>
Size	Φ 150*260(H)MM
LED power	12W SMD
Luminous Flux	70~80LM/W
Input Voltage	AC85~265V
Working Frequency	50/60HZ
Color Temperature	WW: 2700~3200K NW: 4000~4500K W: 5500~6500K
CRI	Ra>80
Beam Angle	120°
Color of Shell	Black
Material	Aluminum alloy
IP rate	IP65
Working Temperature	-20 to +60 °C
Working Humidity	10-70% RH
Certificate	CE RoHS
Warranty	3 year

● Product Package

Box size	Box/carton	Carton size	Net Weight (pcs)	Gross weight (pcs)
32*16.5*16.5CM	9pcs	35*52*52cm	2.2g	2.4kg

● Installation Instructions

1. Please turn off the original power before installation;
2. If there is an electronic ballast, it can not be installed directly, you should get rid of the electronic ballast;
3. Non-professionals should not disassemble the LED lamp by themselves;
4. If there is any unusual problems happen when using, please contact us in time. The product should not be opened optionally, or no warranty for it.

● Detailed Pictures

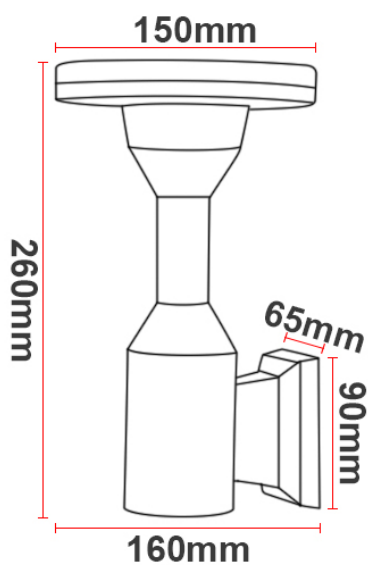

● Products Application Cases

Replacement for stairs, bedrooms, hotels, conference/meeting rooms, offices, commercial complexes, restaurants & clubs, residential buildings, schools, colleges and universities, hospitals, supermarkets, warehouses and etc.



